

Halsey Taylor® Owners Manual

Fully-Recessed Barrier-Free Water Cooler

Model
RC



Model
RC W/CUP DISPENSER



INSTALLER

To assure you install these models easily and correctly, PLEASE READ THESE SIMPLE INSTRUCTIONS BEFORE STARTING THE INSTALLATION. CHECK YOUR INSTALLATION FOR COMPLIANCE WITH PLUMBING, ELECTRICAL, AND OTHER APPLICABLE CODES. After installation, leave these instructions with the Water Cooler for future reference.

IMPORTANT

ALL SERVICE TO BE PERFORMED BY AN AUTHORIZED SERVICE PERSON

IMPORTANT! INSTALLER PLEASE NOTE.

THE GROUNDING OF ELECTRICAL EQUIPMENT SUCH AS TELEPHONE, COMPUTERS, ETC. TO WATER LINES IS A COMMON PROCEDURE. THIS GROUNDING MAY BE IN THE BUILDING OR MAY OCCUR AWAY FROM THE BUILDING. THIS GROUNDING CAN CAUSE ELECTRICAL FEEDBACK INTO A FOUNTAIN, CREATING AN ELECTROLYSIS WHICH CAUSES A METALLIC TASTE OR AN INCREASE IN THE METAL CONTENT OF THE WATER. THIS CONDITION IS AVOIDABLE BY USING THE PROPER MATERIALS AS INDICATED. ANY DRAIN FITTINGS PROVIDED BY THE INSTALLER SHOULD BE MADE OF PLASTIC TO ELECTRICALLY ISOLATE THE FOUNTAIN FROM THE BUILDING PLUMBING SYSTEM.

OPERATION OF QUICK CONNECT FITTINGS

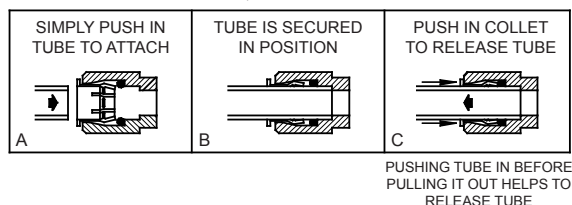

FIG. 1

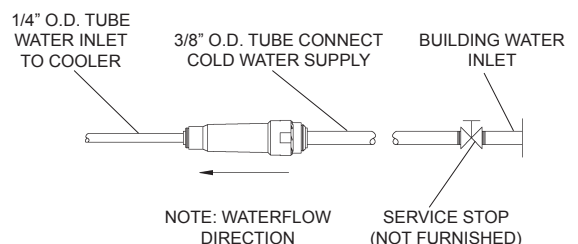

FIG. 2

WALL FRAME INSTALLATION INSTRUCTIONS
FOR THE
RC MODELS DRINKING FOUNTAIN
 (with and without cup dispenser)

1. **Cut** a wall opening 24 7/8 W x 48 1/2 H (with cup dispenser), 17 1/8 W x 48 1/2 H (without cup dispenser). The bottom edge of the opening should be approx. 16 1/8" above the floor (See Fig. 3 with cup dispenser). See Fig. 4 without cup dispenser. Check local codes for height requirement.
2. **After** opening is completed, reinforce opening on all sides so that it may adequately support water cooler which weighs up to 150 lbs. and also provides a means of securing Wall Frame in place. (Install a wall stud indicated on Fig. 3 (with cup dispenser). NOTE: Building construction must allow for adequate airflow on both sides and top of chiller unit. 4" minimum required).
3. **Install** rough plumbing to fountain. See Fig. 5 for location of supply water inlet to chiller and location of waste water outlet.

***For cup dispenser model without glass filler plumbing, continue with step no. 5.**

4. **(Cup dispenser Models)** Install rough plumbing to cup dispenser. See Fig. 15 for location of waste water outlet.
5. **Cut** plastic ties holding chiller shelf support rods to framework.
6. **Install** wall frame assembly in wall opening with front edge of frame flush with finished wall face. Secure frame through holes in top and sides to wall support members with 5/16" diameter fasteners (bolts or lag screws) as required by wall constructions. (14) bolts/screws required. CAUTION: DO NOT USE LESS THAN REQUIRED QUANTITY AND SIZE (DIAMETER) OF FASTENERS.
7. **Install** chiller shelf. Place shelf on lower frame member and attach support rods. Secure front edge of the frame and wall construction using two 5/16" diameter lag screws or bolts. Tighten securely.
8. **Install** electrical conduit. Fig. 5 shows electrical conduit connection location.
9. **Now** you are ready to install fountains.

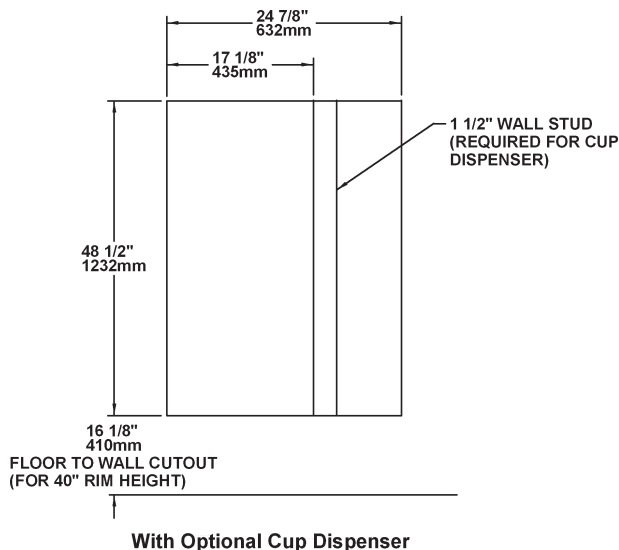

FIG. 3

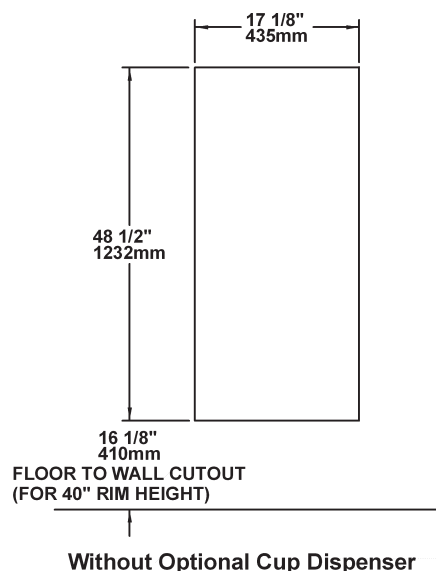

FIG. 4

PLUMBING ROUGH-IN

* NOTE: If wall opening height has been adjusted to meet local codes (see Step No. 1 of installation instructions), height dimensions must be adjusted accordingly.

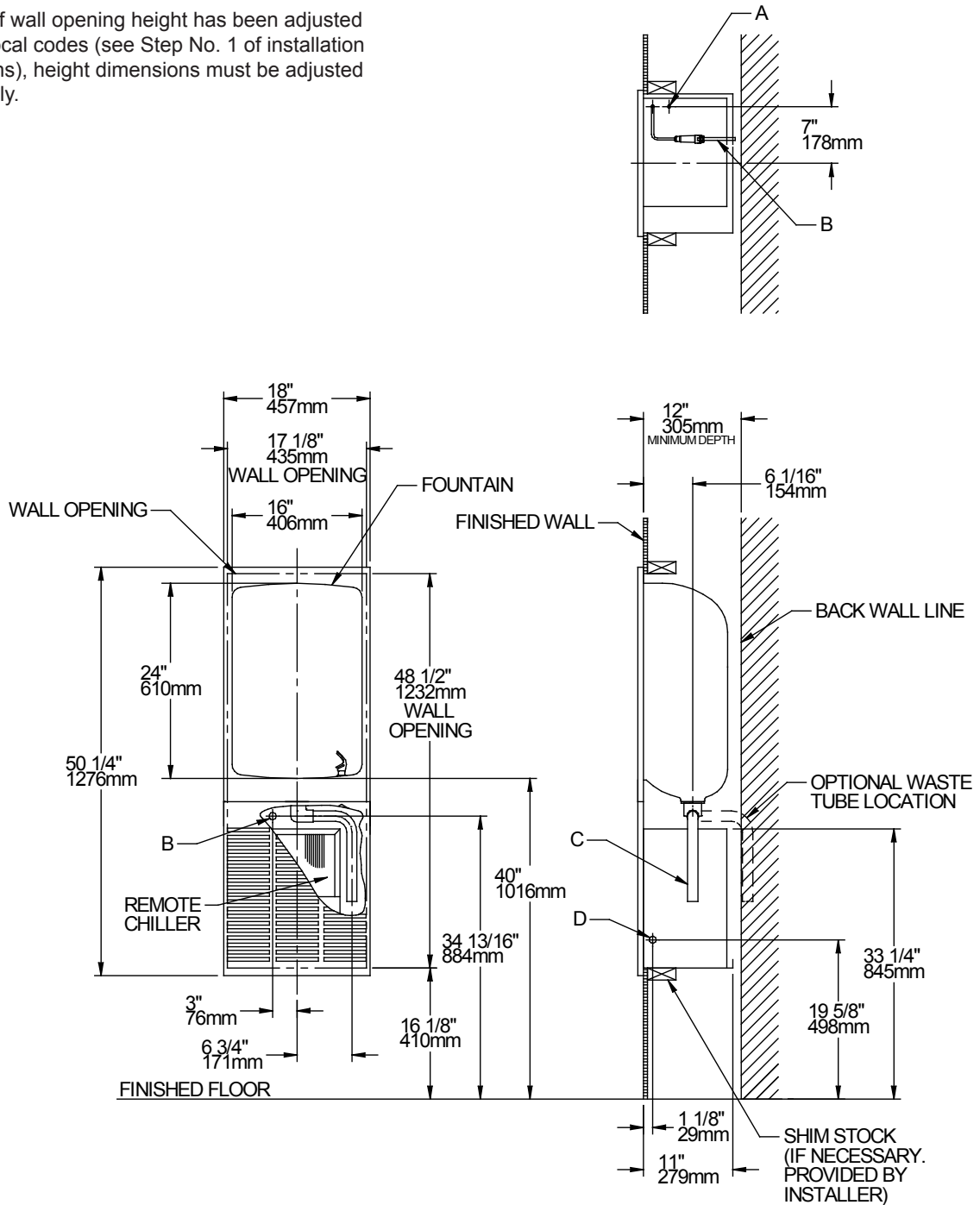

FIG. 5

LEGEND

- A = 1/4" O.D. TUBE CONNECT (CHILLER WATER OUTLET)
- B = 3/8" O.D. TUBE CONNECT (CHILLER WATER INLET) SHUT OFF VALVE BY OTHERS
- C = 1-1/4" O.D. WASTE WATER OUTLET TUBE (TRAP NOT FURNISHED)
- D = ELECTRICAL INLET

Note: Danger! Electric shock hazard. Disconnect power before servicing unit.

USES HFC-134A REFRIGERANT

INSTALLATION INSTRUCTIONS
RC MODELS DRINKING FOUNTAIN
 (refrigerated and non-refrigerated)

1. **Familiarize** yourself with the RC Wallframe which should already be in place in the wall. If not, refer to the "RC Wallframe" Installation Instructions before proceeding.
2. **Determine** location of rough plumbing. At this point, you should decide which style trap you plan to use. For easier installation, we recommend the use of a swivel trap.
3. **Install** the basin (See Fig. 7). Hold the basin flush against the wall, positioning the top edge just above the upper edge of the wall frame. Then slide the basin down slowly until it engages the hanger bracket. Be sure the basin is firmly engaged before releasing it.
4. **Finish** securing basin in place. Align the brackets at the bottom of the basin with the bracket on the frame. Fasten the brackets together using screws and speednuts (provided with fountain).
5. **Install** tailpiece assembly. Slide the slip nut and gasket from the trap onto the tailpiece. Insert the tailpiece assembly into the trap and align its other end with the drain hole in the basin. Place rubber gasket between the tailpiece assembly and the basin, then screw in the drain plug from above. Tighten the drain plug. Tighten slip nut and swivel joint. Snap the strainer plate into the drain plug.
6. **Install** a service stop (not provided) on the supply water inlet line. Turn on supply water and flush thoroughly.
7. **Install** refrigeration unit. Slide refrigeration unit into the wallframe and position tight against left side and flush with the front edge of wallframe. **WARNING:** Adequate space must be maintained behind the refrigeration unit for air circulation.
8. **Water** supply connections (See Figs. 8, 9, & 10)

RC8A Models – Make connections between remote chiller and building supply line. Inlet port is marked on the chiller (1/4" O.D. copper tube). Bend the copper tube (provided) at an appropriate length from chiller to opening in frame. Install the in-line strainer (provided with chiller) by pushing it in until it reaches a positive stop, approximately 3/4" (19mm) on the marked chiller inlet port. Connect building supply line to strainer. **DO NOT SOLDER TUBES INSERTED INTO THE STRAINER AS DAMAGE TO THE O-RINGS MAY RESULT.** (See Fig. 8) **Make connections between remote chiller outlet tube and fountain.** Outlet port is marked on the chiller (1/4" O.D. copper tube). Install a 1/4" x 1/4" union (provided) on the marked chiller outlet port. Insert the 1/4" poly tubing coming from the fountain into the union. Turn on the water supply and check for leaks. **DO NOT SOLDER TUBES INSERTED INTO THE UNION AS DAMAGE TO THE O-RINGS MAY RESULT.** (See Fig. 8)

9. **RC8A Model Filter units.** Mount filter head assembly to side of chiller (See Figure 11). Make connections between filter and building supply line (3/8" O.D. tube not provided). Inlet port is marked on the chiller (1/4" O. D. copper tube). Install a 1/4" x 1/4" union (provided) on the marked chiller inlet port. Insert the 1/4" poly tubing (provided) into the fitting on filter and connect the union to the chiller. **DO NOT SOLDER TUBES INSERTED INTO THE UNION/TEE AS DAMAGE TO THE O-RINGS MAY RESULT.**(See Figure 11)

RC12A Models – Make connections between precooler and building supply line. Install the in-line strainer (provided with chiller) by pushing it in until it reaches a positive stop, approximately 3/4" (19mm) on the precooler inlet tube. Connect building supply line to strainer. **DO NOT SOLDER TUBES INSERTED INTO THE STRAINER AS DAMAGE TO THE O-RINGS MAY RESULT.** (See Fig. 10)

Make connections between precooler and remote chiller. Inlet port is marked on the chiller (1/4" O.D. copper tube). Bend the copper tube (provided) at an appropriate length from chiller and install a 1/4" x 3/8" union (provided) on the marked chiller inlet port. Insert the precooler outlet tube into the union. **DO NOT SOLDER TUBES INSERTED INTO THE UNION AS DAMAGE TO THE O-RINGS MAY RESULT.** (See Fig. 10)

Make connections between remote chiller outlet tube and fountain. Outlet port is marked on the chiller (1/4" O.D. copper tube). Install a 1/4" x 1/4" union (provided) on the marked chiller outlet port. Insert the 1/4" poly tubing coming from the fountain into the union. Turn on the water supply and check for leaks. **DO NOT SOLDER TUBES INSERTED INTO THE UNION AS DAMAGE TO THE O-RINGS MAY RESULT.** (See Fig. 10)

10. **GF Model Only. Make connections between remote chiller outlet tube and fountain.** Outlet port is marked on the chiller (1/4" O.D. copper tube). Install a 1/4" x 1/4" tee (provided) on the marked chiller outlet port. Insert the 1/4" poly tubing coming from the fountain into the tee. Connect glass filler line to outlet on tee. Install a 1/4" x 3/8" union (provided) on the glass filler outlet line. Insert a piece of 1/4" poly tubing from the tee to the union. Turn on the water supply and check for leaks. **DO NOT SOLDER TUBES INSERTED INTO THE UNION/TEE AS DAMAGE TO THE O-RINGS MAY RESULT.** (See Fig. 9)
10. **Open** service stop and operate push button to purge air. Check thoroughly for leaks.

11. **Check** stream height from bubbler. Stream height is factory set at 45 – 50 PSI. If supply pressure varies greatly from this, remove items 14 & 15 and adjust screw on regulator (item 11). Clockwise adjustment will raise stream height and CCW adjustment will lower stream height. For best adjustment, stream height should be approximately 1-1/2" (38mm) above the bubbler guard. (See Fig. 6)
12. **Connect** refrigeration unit to electrical supply and check for proper operation. **WARNING:** Adequate space must be maintained behind the refrigeration unit for air circulation.
13. **Attach** regulator holder (item 10) to grill (item 3) with hex nut (item 13). Hold grill and engage angle on top edge of grill with lower edge of basin. Swing bottom of grill into place against the wall and securing grill mounting screws (provided).

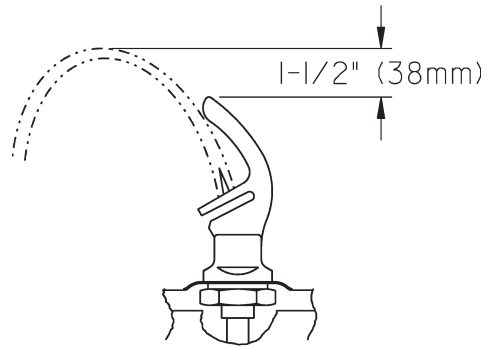

CORRECT STREAM HEIGHT

FIG. 6

BASIN INSTALLATION

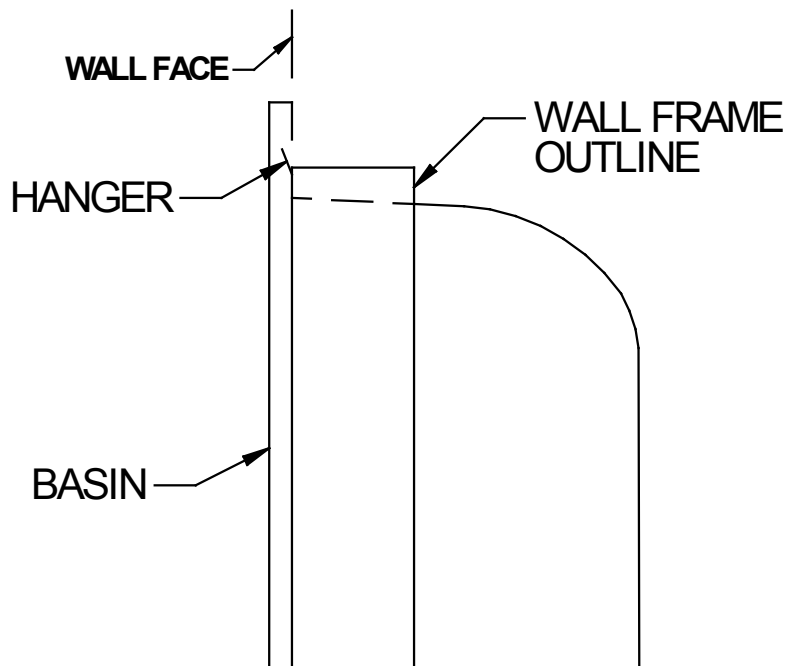

FIG. 7

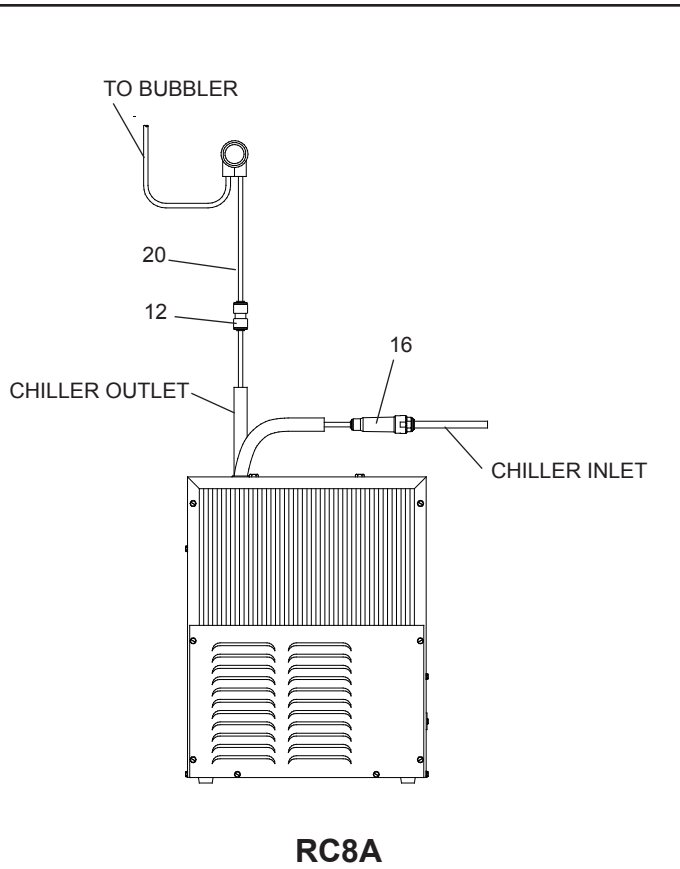

FIG. 8

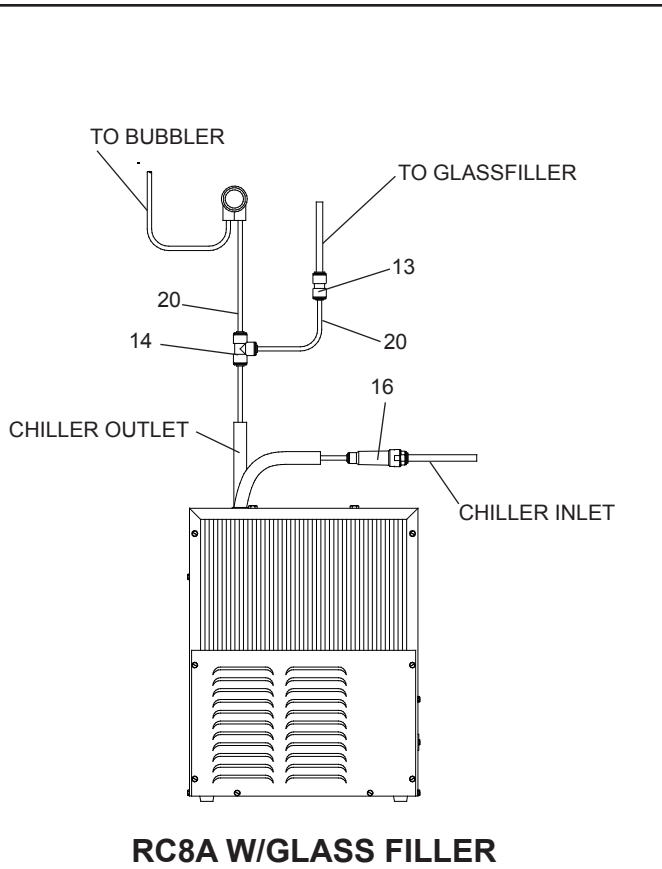
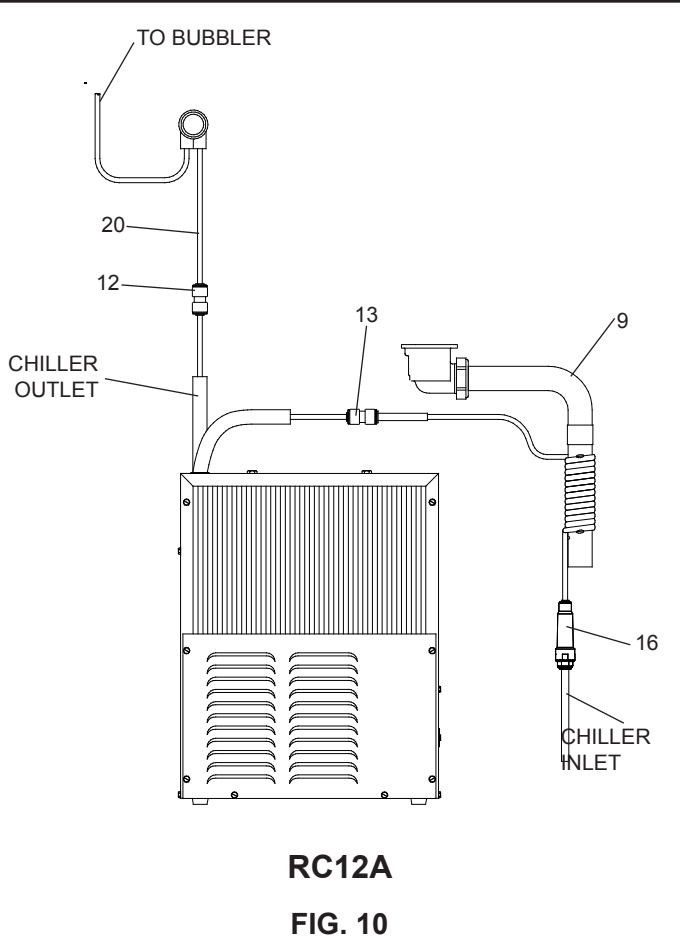
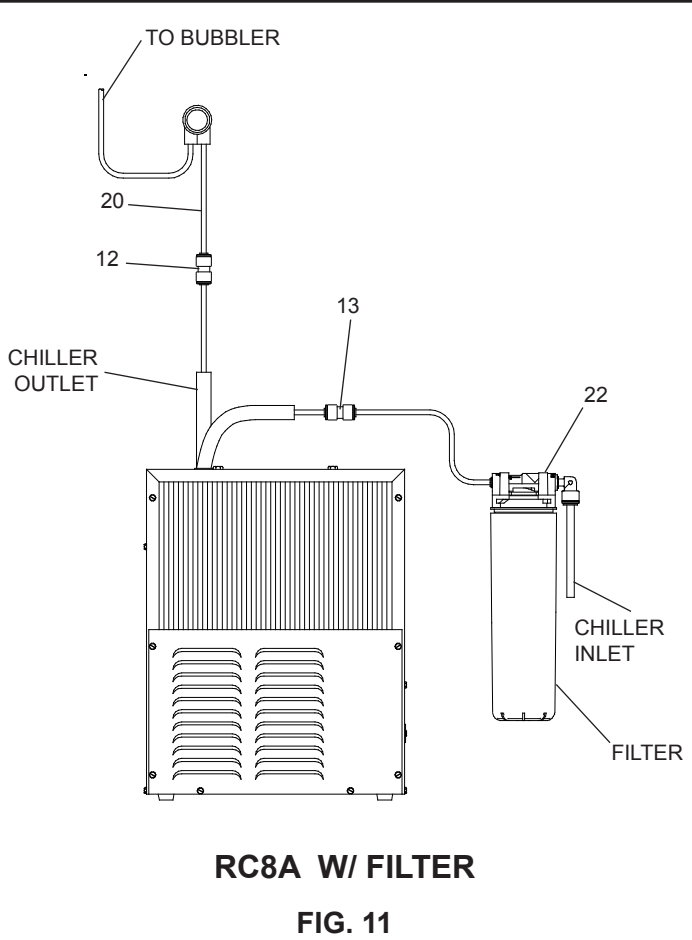

FIG. 9



RC12A
FIG. 10



RC8A W/ FILTER
FIG. 11

INSTALLATION INSTRUCTIONS
FOR THE
RC CUP DISPENSER OPTION
MODELS: 14762

1. **Open** door of cup dispenser and remove waste bin.
2. **Shim** along the bottom and side of cup dispenser as required to obtain a good alignment with previously installed drinking fountain. Be sure to check for proper operation of access door before securing unit in place. Securing can be done through slots provided using screws or bolts (as required by wall construction).
3. **Replace** waste bin.

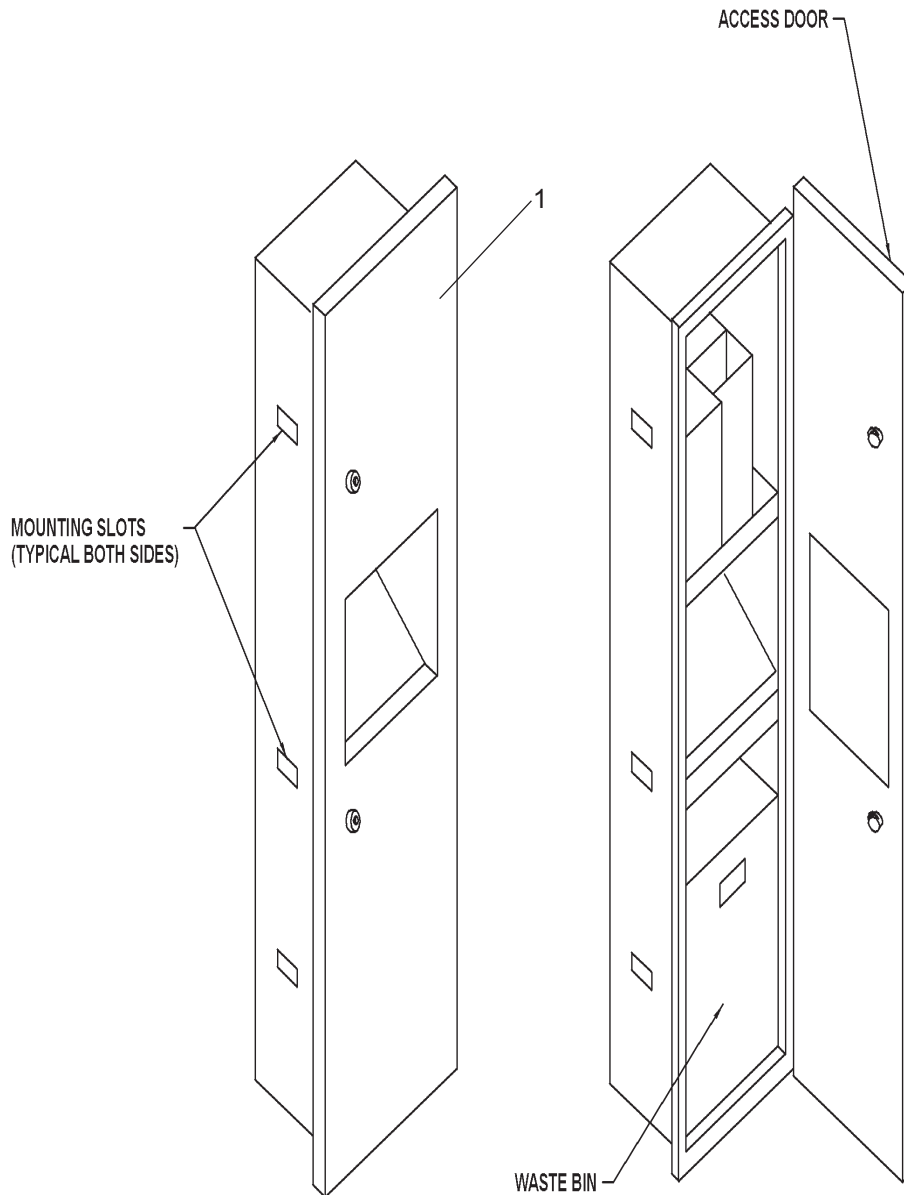

FIG. 12

PLUMBING ROUGH-IN
CUP DISPENSER

* NOTE: If wall opening height has been adjusted to meet local codes (see Step No. 1 of installation instructions), height dimensions must be adjusted accordingly.

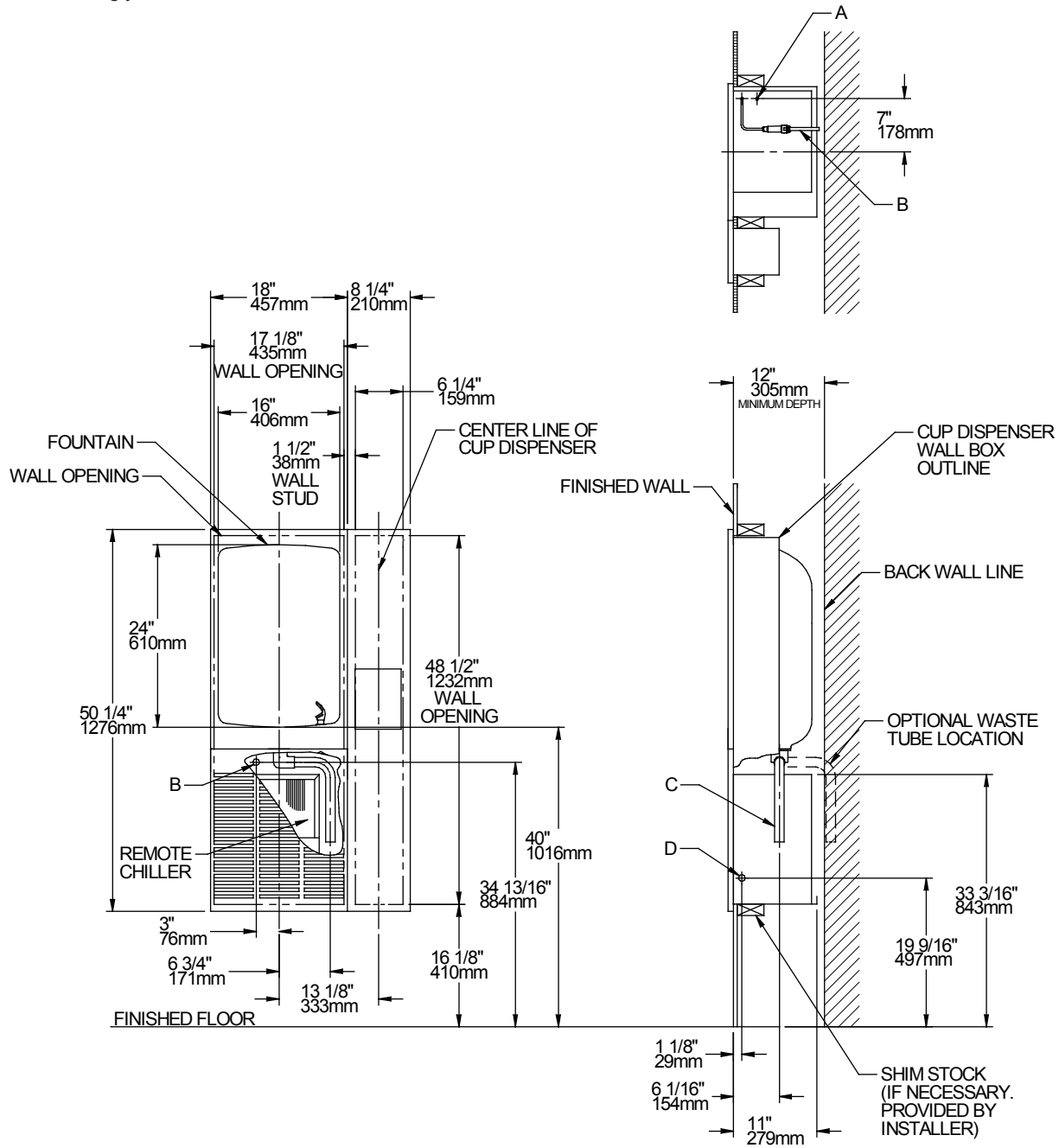

FIG. 13

LEGEND

- A = 1/4" O.D. TUBE CONNECT (CHILLER WATER OUTLET)
- B = 3/8" O.D. TUBE CONNECT (CHILLER WATER INLET) SHUT OFF VALVE BY OTHERS
- C = 1-1/4" O.D. WASTE WATER OUTLET TUBE (TRAP NOT FURNISHED)
- D = ELECTRICAL INLET

Note: Danger! Electric shock hazard. Disconnect power before servicing unit.*USES HFC-134A REFRIGERANT*

INSTALLATION INSTRUCTIONS
RC MODEL DRINKING FOUNTAIN
 (Cup Dispenser With Glass Filler)

1. **The 14700 Model Cup Dispenser with Glassfiller** is designed to complement model RC drinking fountains. The fountain should already be installed before beginning installation. If not refer to page 2 for your model. Remove louvered access panel from fountain via the two screws at the bottom.
2. **Check** wall opening to see if provisions have been made to accept this cup dispenser. If they have not, refer to page 2 for rough-in instructions. CAUTION: Wall construction must be framed to support fountain and cup dispenser (approximately 150 pounds).
3. **See** Parts List Illustration (page 10) for cup dispenser tailpiece. Decide which style of waste trap you intend to use. For easier installation, we recommend the use of a swivel trap.
4. **Orientate** yourself to the configuration of the cup dispenser. Open front door and remove the spring loaded trash access panel. To remove access panel, just loosen the four mounting screws and pull out the panel. Also remove the waste bin. Note location of mounting slots in the wall box portion of the cup dispenser. The slots are for affixing wallbox to building construction.
5. **Put** cup dispenser in wall opening. Determine shimming required to obtain a good alignment with fountain. Open and close door to ensure proper operation. CAUTION: Do not "suspend" cup dispenser via the mounting slots - be sure to shim along bottom edge to bear the weight of the cup dispenser.
6. **Secure** cup dispenser in place. Use lag screws or bolts as required by wall construction.
7. **Install** glass filler supply tube assembly. (See Figure 14). Put glass filler fitting through hole provided in back, put gasket on from the front and screw on the hexagonal mounting nut.
8. **Install** glass filler. First remove the blue handle, then screw the glass filler into the glass filler fitting. Reattach blue handle.
9. **Make connections between remote chiller outlet tube and fountain.** Outlet port is marked on the chiller (1/4" O.D. copper tube). Install a 1/4" x 1/4" tee (provided) on the marked chiller outlet port. Insert the 1/4" poly tubing coming from the fountain into the tee. Connect glass filler line to outlet on tee. Install a 1/4" x 3/8" union (provided) on the glass filler outlet line. Insert a piece of 1/4" poly tubing from the tee to the union. Turn on the water supply and check for leaks. **DO NOT SOLDER TUBES INSERTED INTO THE UNION/TEE AS DAMAGE TO THE O-RINGS MAY RESULT.** (See Fig. 9)
10. **RC8A Model Filter units.** Mount filter head assembly to side of chiller (See Figure 11). Make connections between filter and building supply line (3/8" O.D. tube not provided). Inlet port is marked on the chiller (1/4" O. D. copper tube). Install a 1/4" x 1/4" union (provided) on the marked chiller inlet port. Insert the 1/4" poly tubing (provided) into the fitting on filter and connect the union to the chiller. **DO NOT SOLDER TUBES INSERTED INTO THE UNION/TEE AS DAMAGE TO THE O-RINGS MAY RESULT.**(See Figure 11)
11. **Install** tailpiece assembly (as shown in Figure 15). Connect waste trap (not provided).
12. **Turn** on supply water and operate push button valve and glass filler. Check entire system for leaks. Water flow from the glass filler can be adjusted by turning the flow adjusting screw (See Figure 14). In order to adjust, it may be necessary to remove, and then reinstall the glass filler, per step 8 above.
13. **Replace** the spring loaded trash access panel via the four mounting screws. Reinstall louvered grill on the fountain.

ITEMIZED PARTS LIST

ITEM NO.	PART NO.	DESCRIPTION
1	101470051830	Disp - Cup w/GF Provisions (See Fig. 11)
2	160807751640	Assy - Valve Push Back
3	411564208640	Nut - Hex
4	100115824740	Gasket
5	100147140560	Gasket - Drain
6	100352940560	Gasket - Slip Nut
7	110346220550	Nut - Hex
8	160270508640	Strainer - Plate
9	160346008640	Tailpipe 1-1/4 x 4
10	160346308640	Nut - Slip 1-1/2
11	161637308640	Plug - Drain 1-1/2
12	66710C	GF Tube for 14700 Disp

IMPORTANT: Fountain and glassfiller are rated for a supply pressure of 90 PSI minimum. If supply pressure exceeds this, a pressure reducing regulator should be installed on the supply line. Minimum supply pressure - 15 PSI.

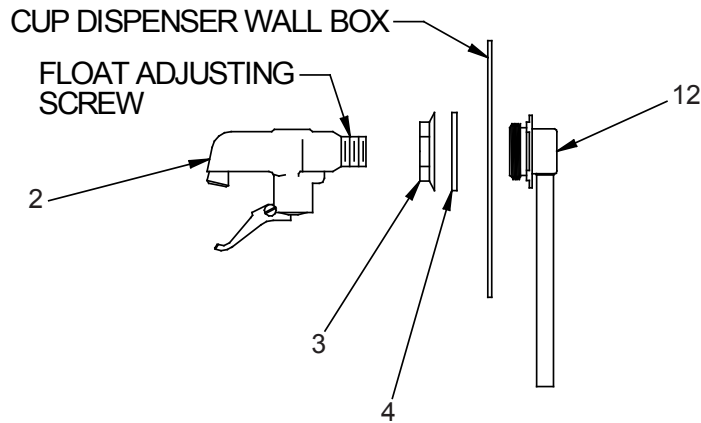

FIG. 14

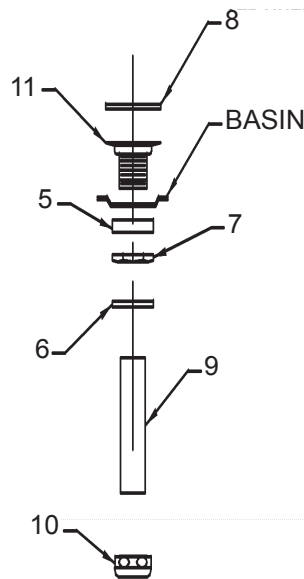

FIG. 15

PLUMBING ROUGH-IN CUP DISPENSER WITH GLASS FILLER

* NOTE: If wall opening height has been adjusted to meet local codes (See Step No. 1 of installation instructions), height dimensions must be adjusted accordingly.

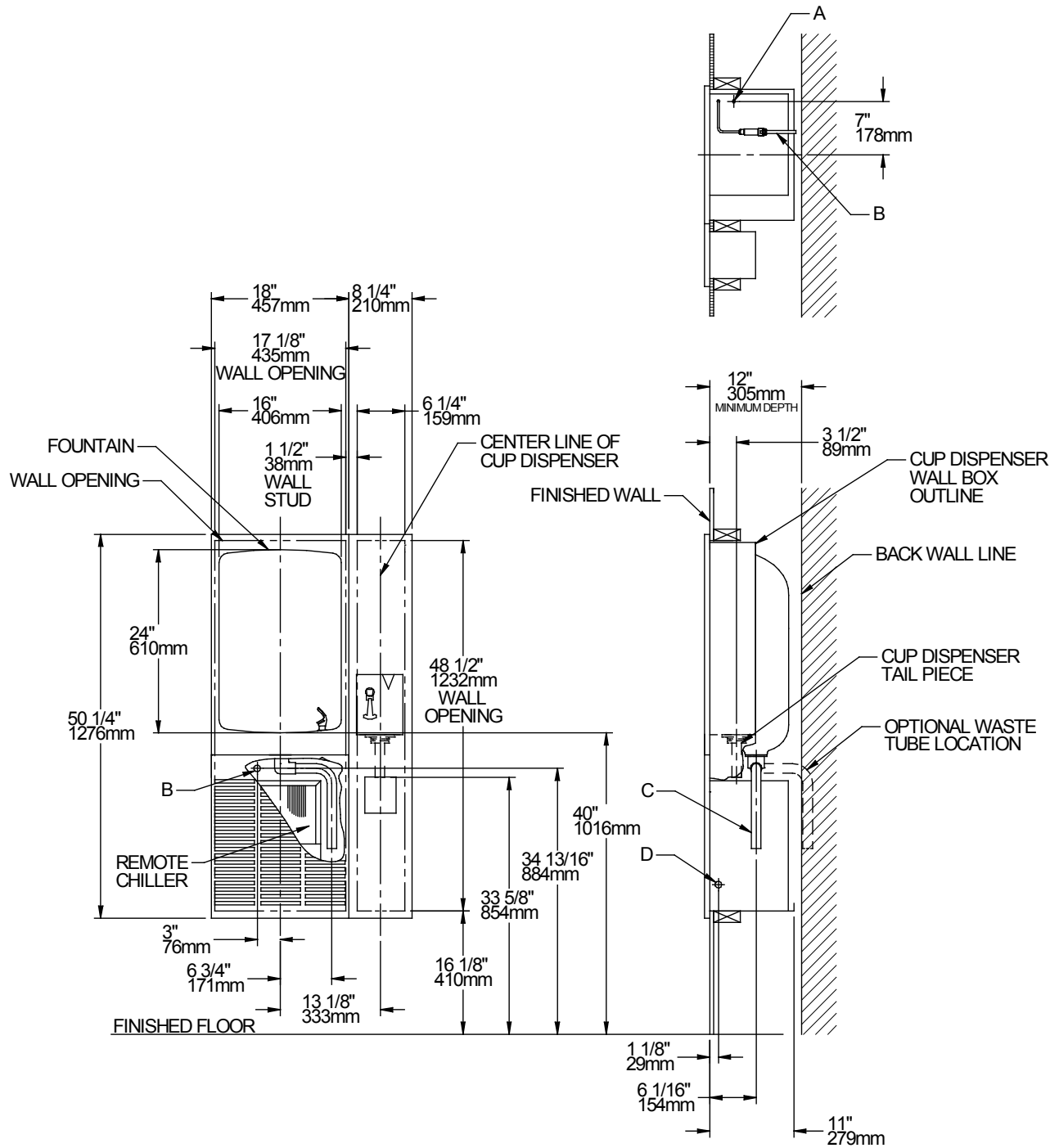

FIG. 16

LEGEND

- A = 1/4" O.D. TUBE CONNECT (CHILLER WATER OUTLET)
- B = 3/8" O.D. TUBE CONNECT (CHILLER WATER INLET) SHUT OFF VALVE BY OTHERS
- C = 1-1/4" O.D. WASTE WATER OUTLET TUBE (TRAP NOT FURNISHED)
- D = ELECTRICAL INLET

ITEMIZED PARTS LIST

ITEM NO.	PART NO.	DESCRIPTION
1	1000002412	Basin
2	732660951550	Mounting Frame
3	23040C	Grill
4	100147140560	Gasket - Drain
5	160270508640	Strainer Plate - Chrome
6	161637308640	Drain Plug - Chrome
7	51546C	Bubbler - Chrome
8	100322740560	Gasket - Bubbler (2-Req'd)
9	97017C	Kit - Waste Tube/Elbow/Nut Wshr/RC8
	97310C	Kit - Waste Line/Precooler Assy-RC12
10	98536C	Kit - Push Button Assy
11	62300C	Tube Assy - Bubbler 8880
12	1000002162	Kit - Union 1/4 (3 Pack)
13	70745C	Fitting - Union 1/4 x 3/8
14	1000001994	Kit - Tee 1/4" (3 Pack)
15	74050011	Sound Dampening Pad
16	55996C	In - Line Strainer
17	74070030	Screw - #8 x 1.00 PHSM
18	56121C	Elbow - Drain
19	75588C	Nut - Slip Joint 1-1/4
20	56092C	Poly Tubing (Cut To Length)
21	75589C	Gasket
22	HWF172	Filter Assembly

TROUBLE SHOOTING AND MAINTENANCE

Orifice Assy: Mineral deposits on orifice can cause water flow to spurt or not regulate. Mineral deposits may be removed from the orifice with a small round file not over 1/8" diameter or small diameter wire. **CAUTION: DO NOT** file or cut orifice material.

Stream Regulator: If orifice is clean, regulate flow as in instructions. If replacement is necessary, see parts list for correct regulator part number.

Actuation of Quick Connect Water Fittings: Cooler is provided with lead-free connectors which utilize an o-ring water seal. To remove tubing from the fitting, relieve water pressure, push in on the gray collar while pulling on the tubing. (See Fig.1) To insert tubing, push tube straight into fitting until it reaches a positive stop, approximately 3/4".

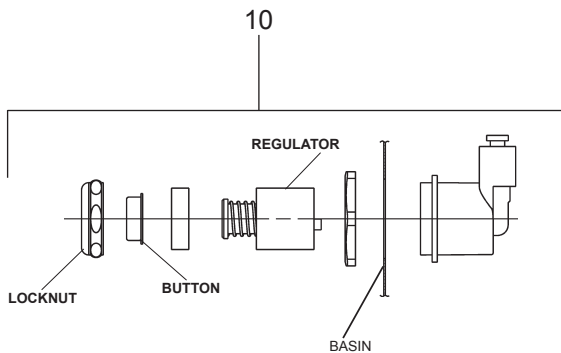

Stream height is factory set at 35 PSI. If supply pressure varies greatly from this, remove Locknut and Button and adjust screw on Regulator. Clockwise adjustment will raise stream and counter-clockwise adjustment will lower stream. For best adjustment, stream should hit basin approximately 6-1/2" (165mm) from bubbler.

FIG. 17

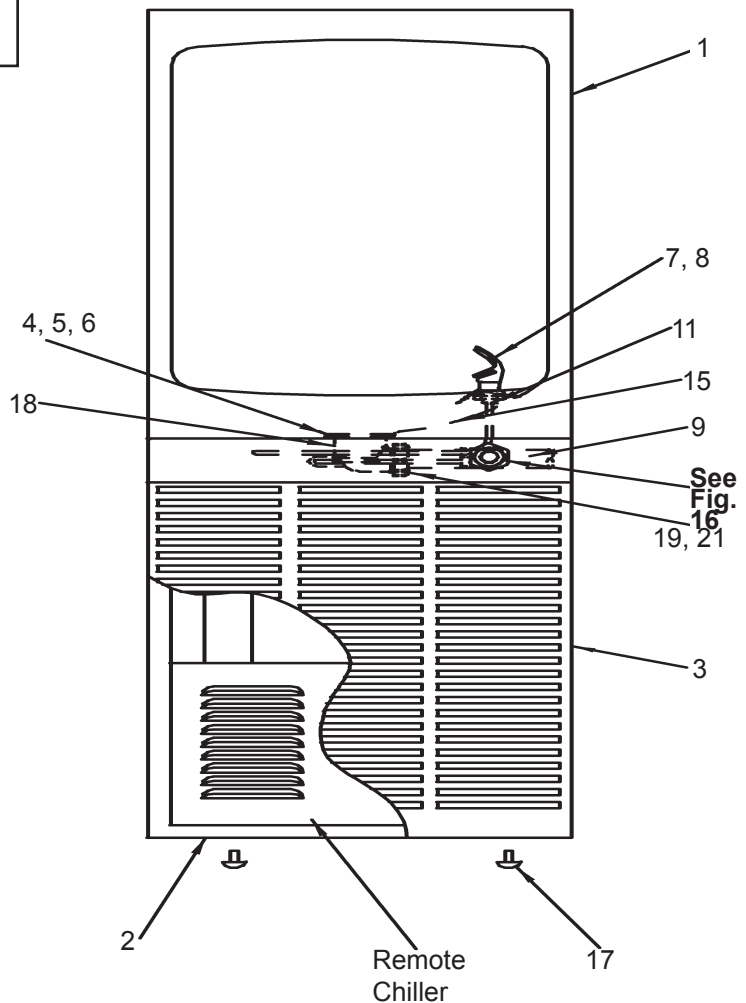

FIG. 18

Halsey Taylor
 2222 CAMDEN COURT
 OAK BROOK, IL 60523
 630.574.3500