

THIS SPACE FOR DESIGNER/ENGINEER APPROVAL

Job/Customer _____	Date _____	Contractor _____
Model Specified _____	Qty _____	Approved By _____
Designer/Engineer _____	Date _____	Contractor's PO# _____
Submitted By _____	Date _____	Other _____

4064 Series
Full Port Forged Brass Ball Valves
3 Way L-Port w/ Reversible Handle
IPS
600 WOG / 150 WSP
ISO 9001

ITEM #	SIZE	CTN	CASE	A	B	C	D	E	F	Cv
40642	1/2"	15	60	1/2	2 1/8	1 3/4	3 1/4	1	1 11/16	10.8
40643	3/4"	10	40	3/4	2 7/16	2 1/8	4	1 1/4	2	26.8
40644	1"	6	24	1	2 15/16	2 3/8	4 5/8	1 7/16	2 7/16	47.4



NO.	DESCRIPTION	MATERIAL
1	BODY	BRASS
2	END CAP	BRASS
3	SEAT	PTFE
4	BALL	BRASS HCP
5	STEM	BRASS
6	STEM SEAL	PTFE
7	PACKING GLAND	BRASS
8	HANDLE	STEEL CP
9	HANDLE NUT	STEEL CP
10	HANDLE JACKET	VINYL

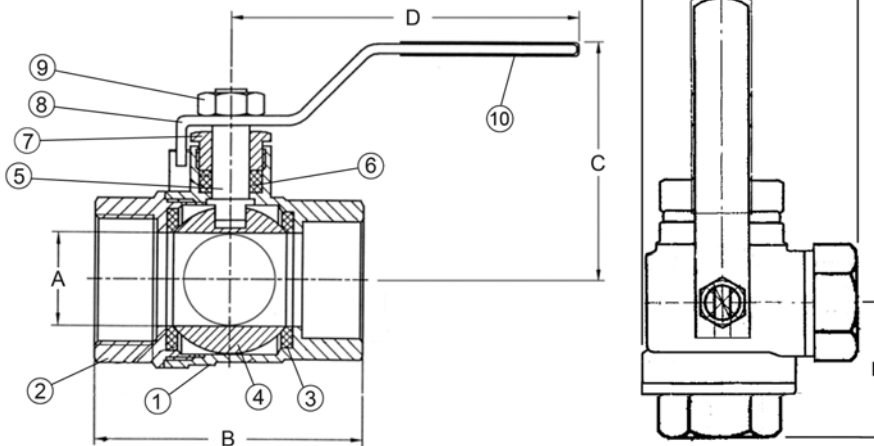

TEMP °F	PSI
100	600
150	490
200	470
250	439
300	411
350	294
366	N/A

Specifications: Designed for residential, commercial or industrial use with water, oil or gas. This approved Webstone valve is actuated by a blowout proof stem and features an adjustable packing gland. Threaded ends comply with ANSI B1.20.1



Quality and Commitment Since 1954

Tel: (800) 225-9529 • Fax (800) 336-5133

Webstone product specifications in U.S. customary units are approximate and are provided for reference only. Webstone reserves the right to change or modify product design, construction, specifications or materials without prior notice and without incurring any obligation to make such changes and modifications on Webstone products previously or subsequently sold.