

## 200 PSI Butterfly Valves

Cast Iron Body • Extended Neck • Cartridge Seat Liner\* • Lug Style

Sizes 2" through 12"

Install between Std. ASME Class 125 flanges†.

Bi-directional dead end service rating without a downstream flange required: 2"-6" 200 PSI, 8" 150 PSI, 10"-12" 100 PSI.

THIRD PARTY CERTIFIED BY QAI TO MEET MSS SP-67 STANDARD

### MATERIAL LIST

PART	SPECIFICATION
1. Body	Cast Iron, Epoxy coated ASTM A126 CL.B
2. Body Bushing	Bronze ASTM B584 Grade C83600
3. Liner	EPDM Rubber w/Phenolic Backing Buna-N Rubber Nitrile w/Phenolic Backing
4. Stem	Stainless Steel ASTM A582 Type 416
5. Disc	Ductile Iron ASTM A536 Grade 65-45-12 (nylon bonded)
6. Taper Pin (2 pin 6" - 12")	Stainless Steel ASTM A582 Type 416
7. Name Plate	Aluminum
8. Shaft Bushing	Bronze ASTM B584 Grade C83600
9. Stem Seal	Buna-N Rubber Nitrile

### DIMENSIONS — WEIGHTS

Size	A	Min.	B	C	E		F	G	H	I	
In. mm.	Dia.	Pipe I.D.	Dia.	Dia.	D			Body	Seat	Dia.	
2	50	2.08	1.38	3.00	3.94	6.34	1.26	10.75	1.655	1.81	0.496
2 1/2	65	2.54	1.95	3.50	4.72	6.89	1.26	11.65	1.759	1.93	0.496
3	80	3.10	2.66	4.09	5.00	7.13	1.26	12.12	1.780	1.93	0.496
4	100	4.10	3.67	5.32	6.14	7.87	1.26	13.62	2.050	2.18	0.621
5	125	4.85	4.48	6.26	7.48	8.39	1.26	14.65	2.140	2.31	0.745
6	150	6.12	5.84	7.42	8.35	8.90	1.26	15.62	2.195	2.33	0.745
8	200	7.97	7.85	9.38	10.55	10.24	1.77	18.88	2.385	2.52	0.870
10	250	9.86	9.76	11.51	12.79	11.50	1.77	21.26	2.584	2.83	1.120
12	300	11.87	11.72	13.55	15.87	13.27	1.77	24.57	3.029	3.19	1.244

Size	J	K	L	M	R	Q	T	Lug Weight		
In. mm.	Dia.	B.C. Dia.	Dia.	Dia.	Dia.	Dia.	Flats	Lbs.	Kg.	
2	50	3.00	1.97	0.28	0.75	4.75	4	5/8-11UNC	.350	8.6 3.9
2 1/2	65	3.03	1.97	0.28	0.75	5.50	4	5/8-11UNC	.350	10.8 4.9
3	80	3.03	1.97	0.28	0.75	6.00	4	5/8-11UNC	.350	11.4 5.2
4	100	3.62	2.76	0.39	0.75	7.50	8	5/8-11UNC	.437	18.9 8.6
5	125	3.62	2.76	0.39	0.88	8.50	8	3/4-10UNC	.500	22.8 10.4
6	150	3.62	2.76	0.39	0.88	9.50	8	3/4-10UNC	.500	27.1 12.3
8	200	4.50	4.02	0.47	0.88	11.75	8	3/4-10UNC	.625	41.2 18.7
10	250	4.50	4.02	0.47	1.00	14.25	12	7/8-9UNC	.812	56.3 25.9
12	300	5.50	4.02	0.47	1.00	17.00	12	7/8-9UNC	.875	90.3 41.0

\*Note: refer to NIBCO O & M manual for specified installation instructions for optimal performance of cartridge seat valves

†Note: lug style valves- extra care should be used when installing with raised face flanges. Over-tightening can result in broken lugs.

### N-200238

Lug Style  
EPDM Liner  
Nylon Bonded DI Disc

### N-200138

Wafer Style  
EPDM Liner  
Nylon Bonded DI Disc

### N-200248

Lug Style  
Buna-N Liner  
Nylon Bonded DI Disc

### N-200148

Wafer Style  
Buna-N Liner  
Nylon Bonded DI Disc



Certified to NSF/ANSI 372



P347-1

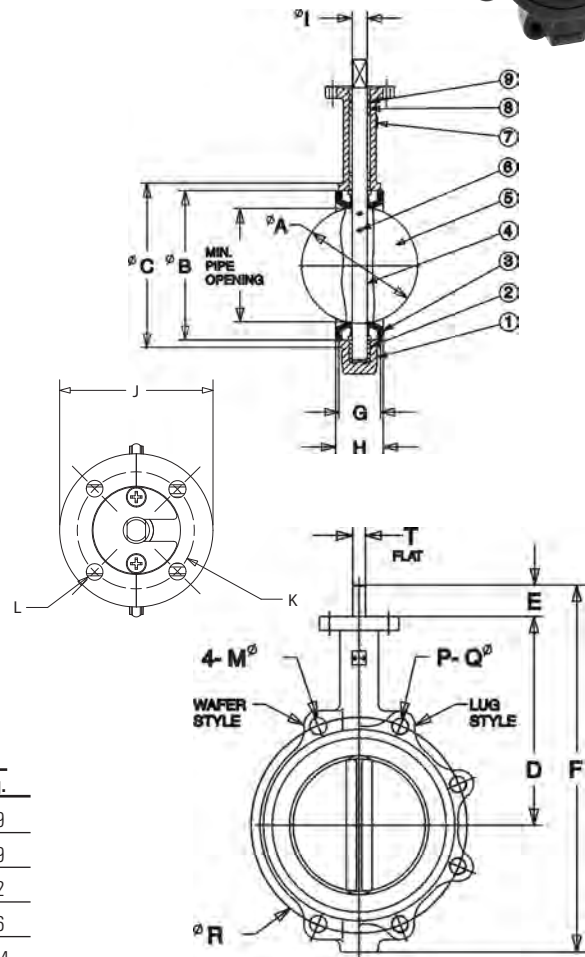

**WARNING:** This product can expose you to chemicals including lead, which is known to the State of California to cause cancer and birth defects or other reproductive harm. For more information go to [www.P65Warnings.ca.gov](http://www.P65Warnings.ca.gov).

NOT RECOMMENDED FOR STEAM SERVICE

Visit our website for the most current information.