



# Technical Sheet

## VersaCooler® II with Hands-Free QUASAR™ VersaFiller

- PG8EBQ
- PGEBQ

### Suggested Specification

Model PG8EBQ shall deliver 8.0 gph of 50°F water at 90°F ambient and 80°F inlet water per ASHRAE 18 testing. Model PGEBQ is a non-refrigerated drinking fountain and delivers ambient water. Shall include the QUASAR sports bottle filler with hands-free activation; fountain shall have four antimicrobial copper push pads to activate the manual flow of water for the cooler.

QUASAR bottle filler shall have UVC-LED treatment at the dispense point, which disinfects the water while it is being dispensed. UVC-LED also cycles on periodically to keep the dispense point sanitized between dispenses.

Hands-free VersaFiller components contain Freshield®, which utilizes a silver-based antimicrobial compound to protect the surfaces from discoloration, odors and degradation caused by the growth of micro-organisms and mildew. Basin shall be designed to eliminate splashing and standing water. Water saver bubbler to reduce waste water by 50% and shall have flexible guard and operate between 20 and 100 PSI. Cabinet finish shall be brushed stainless steel or greystone on galvanized steel. Shall use R-134a refrigerant. Shall comply with ANSI 117.1 and ADA. Shall be listed by Underwriters Laboratories to US and Canadian standards. Shall comply with NSF/ANSI 61 and NSF/ANSI 372.

### Models

- PG8EBQ delivers 8.0 gallons of chilled drinking water per hour.
- PGEBQ is a non-refrigerated fountain.

### Standard Features

- Hands-free QUASAR with mercury-free UVC-LED treatment at the dispense point
- Waterways are Lead-Free in materials & construction
- Flexible one-piece water saver bubbler guard infused with silver based antimicrobial additive
- Stainless steel top and heavy duty galvanized steel frame
- High efficiency cooling system and refrigerant R-134a
- Four antimicrobial copper push pads per fountain
- External stream height adjustment on the drinking fountain
- Built in filter monitor and bottle counter

### Finishes

- Standard cabinet finish: Greystone powder coated paint on galvanized steel
- Optional finishes: Sandstone powder coated paint; Stainless steel (at additional cost)

### Installation

- Prior to roughing consult with local, state and federal codes for proper mounting height
- Shipped with complete instructions and wall mounting bracket
- Removable side and front panels provide easy access for installation.



UVC-LED Treatment right at the point-of-dispense

### Options

- One piece chrome plated brass bubbler (036700-001)
- VersaFilter II
- Remedi Filter

### Limited 5-Year Warranty

(Continental limits of the United States and Canada) Five years on the sealed refrigeration system and most component parts. Detailed warranty certificate enclosed with each water cooler; sample available upon request.

### Export Warranty

One year on components parts. Detailed warranty certificate enclosed with each drinking fountain; sample copy available upon request.

### Certifications/Compliance

- Antimicrobial Copper - EPA Registration No. 89187-3
- Certified to UL 399 and CAN/CSA C22.2 No.120 (electric water coolers only)
- Product Certified to NSF/ANSI Standard 61-G & 372 and conforms with the lead content requirements for "Lead Free" plumbing as defined by California, Vermont, Maryland, and Louisiana state laws and the U.S. Safe Drinking Water Act
- These water coolers comply with the requirements of ADA (Americans with Disabilities Act) when properly installed



**WARNING:**  
Cancer and Reproductive Harm  
[www.P65Warnings.ca.gov](http://www.P65Warnings.ca.gov)



Model	50° F Drinking Water 90° F Ambient Air Temp*			Hot'N Cold™ Model	115 Volts, 60 HZ			Glass Filler Acc. Option	Cabinet Color Finish	Net Wt. Approx.
	Rated Capacity GPH	Base Rate GPH	Pre-Cooler		Compr. HP	Full Load Amps	Rated Watts			
PG8EBQ	8.0	8.0	No	No	1/4	4.6	460	No	Yes	60 Lbs
PGEBQ	Electric Bottle Filler Rating Only					.40	25	No	Yes	28 Lbs

\*Industry standard rating condition 80° F inlet water temperature

Specifications subject to change without notice

# OASIS® VERSACOOLER® II WITH HANDS-FREE QUASAR™

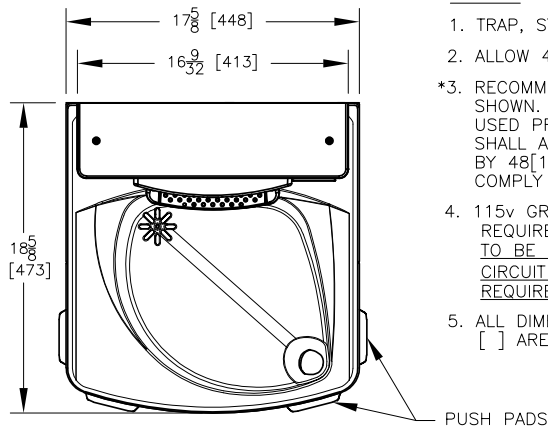

**NOTES:**

1. TRAP, STOP VALVE AND ELECTRICAL OUTLET NOT FURNISHED.
2. ALLOW 4 INCHES [102 MM] MIN. PER SIDE FOR VENTILATION.
- \*3. RECOMMENDED ADULT BARRIER FREE HEIGHT INSTALLATION SHOWN. REDUCE HEIGHT BY 3 INCHES FOR INSTALLATIONS USED PRIMARILY BY CHILDREN AGES 12 AND YOUNGER. UNIT SHALL ALSO HAVE A MINIMUM CLEAR FLOOR SPACE 30[760] BY 48[1220]. ADJUST VERTICAL DIMENSIONS AS REQ'D TO COMPLY WITH FEDERAL, STATE, AND LOCAL CODES.
4. 115v GROUNDING NORTH AMERICAN DUPLEX RECEPTACLE REQUIRED. THIS DRINKING WATER COOLER IS INTENDED TO BE CONNECTED TO A 20A MINIMUM GROUND FAULT CIRCUIT INTERRUPTING (GFCI) DEVICE TO MEET UL REQUIREMENTS.
5. ALL DIMENSIONS ARE IN INCHES. DIMENSIONS IN BRACKETS [ ] ARE IN MILLIMETERS.

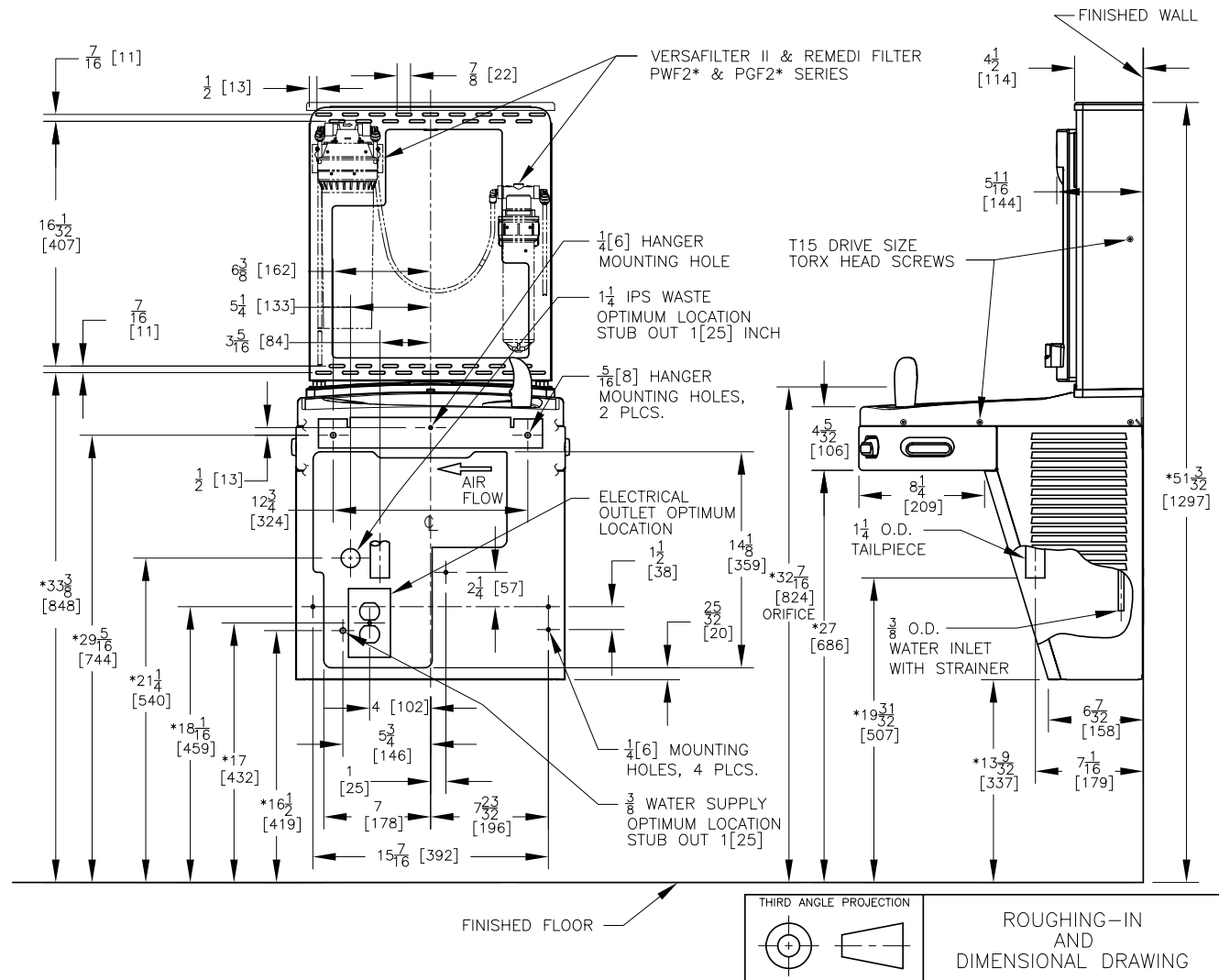

OASIS INTERNATIONAL

[www.oasiscoolers.com](http://www.oasiscoolers.com)

222 East Campus View Blvd.  
Columbus, OH 43235

1-800-646-2747